

# GIRTON PALLET WASHER MODEL CW10PS

## 1. DESCRIPTION

Girton CW10PS Pallet Washer to wash and rinse plastic and metal pallets up to 48" long x 48" wide x 6" high at the rate of 60 to 80 per hour.

## 2. REGULATIONS, CODES AND STANDARDS

All engineering, design, manufacture and testing conforms to all applicable sections of the latest edition of the following codes, standards and specifications in effect at the time of order:

**ASME-BPE** - American Society of Mechanical Engineers

**ANSI** - American National Standard Institute

**ASTM** - American Society for Testing and Materials

**OSHA** - Occupation Safety and Health Administration

**NEMA** - National Electrical Manufacturers Associates

**NEC** - National Electrical Code

**cGMP** - Current Good Manufacturing Practices (CFR Title 21 parts 210 and 211)

**NFPA** - National Fire Protection Association

## 3. DIMENSIONS AND WEIGHT

- 3.1. Left Right Hand
- 3.2. Load Height: 26"
- 3.3. Overall Height: 86"
- 3.4. Overall Width: 53"
- 3.5. Overall Length: 216"
- 3.6. Tunnel Opening: 8" wide x 50" high
- 3.7. Operational Weight: 6,000 lbs.
- 3.8. Pit Dimensions: (If Required) 96" wide x 228" long x 26" deep

## 4. CONSTRUCTION

### 4.1. Material Type and Finish:

- 4.1.1. **Washer Cabinet:** 14 gauge, T-304 T-316L stainless steel  
Interior Finish: mill finish (2B) 35Ra or better 15Ra 8.5Ra  
Exterior Finish: 35Ra or better
- 4.1.2. **Washer Tank:** 14 gauge, T-304 T-316L stainless steel  
Interior Finish: mill finish (2B) 35Ra or better 15Ra 8.5Ra  
Exterior Finish: 35Ra or better
- 4.1.3. **Insulation Jacket:** 20 gauge, T-304 stainless steel,  
Exterior Finish: 35Ra or better
- 4.1.4. **Door:** T-304 T-316L stainless steel  
Interior Finish: mill finish (2B) 35Ra or better 15Ra 8.5Ra  
Exterior Finish: 35Ra or better
- 4.1.5. **Steam Heating Coil:** T-304 T-316L stainless steel  
**Electric Heat:** Incalloy elements

- 4.1.6.  **Steam and Condensate Piping:**  
Interior on Washer: stainless steel  T-304  T-316L schedule 10 pipe  
Exterior on Washer: stainless steel T-304 schedule 40 pipe
- 4.1.7. **Compressed Air:**  
 Tubing  Poly-flo  T-304 stainless steel.
- 4.1.8. **Potable Water Supply Ball Valves:** T-304 stainless steel  
 **Steam Supply Ball Valves:** T-304 stainless steel
- 4.1.9. **Recirculation Header and Piping:** T-316L stainless steel  
Interior Finish:  35Ra or better  Electro-polished to 15 Ra finish  20Ra  
Exterior Finish: 35Ra or better
- 4.1.10. **Purified Final Rinse System:** T-316L stainless steel  
Interior Finish:  35RA or better  Electro-polished to 15 Ra finish  20Ra  
Exterior Finish: 35Ra or better
- 4.1.11. **Sanitary valves:** T-316L stainless steel diaphragm valves  
Interior Finish:  35Ra or better  Electro-polished to 15 Ra finish
- 4.1.12. **Tri-Clamp Clamps:** T-304 stainless steel
- 4.1.13. **Fasteners:** T-304 stainless steel
- 4.2. **Unit Design:**  
 The equipment is designed to be shipped and installed as a **single unit**. Some parts may be removed prior to shipping (i.e., pumps) to decrease the possibility of damages during shipping. The maximum crate size will be approximately \_\_\_\_\_" x \_\_\_\_\_" x \_\_\_\_\_" with an estimated weight of \_\_\_\_\_ lbs.
- Bolted and gasketed** construction allows the washer to be taken down prior to crating. There will be approximately \_\_\_\_\_ # separate pieces and the largest piece will be approximately \_\_\_\_\_" x \_\_\_\_\_" x \_\_\_\_\_" with an estimated weight of \_\_\_\_\_ lbs. A minimum clearance of \_\_\_\_\_" x \_\_\_\_\_" is necessary for access into the building. It is strongly recommended Girton Manufacturing Co., Inc. be contracted to re-assemble or supervise the re-assembly of the equipment due to the custom nature of the equipment.
- 4.3. All **internal corners** have a minimum 5/16" radius.
- 4.4.  See enclosed **Girton's Welding Specification** for information on current in-house welding procedures.
- 4.5. All visible **welds** on the exterior of the washing compartment are thoroughly cleaned. All welds on the interior of the washing compartment are ground and polished.
- 4.6. The **cabinet interior** is constructed to permit free draining and designed not to retain any of the process solutions.
- 4.7. The **wash compartment** is sloped to drain into the pump reservoir through a large stainless steel, basket-type debris screen. The screen is easily removable without the use of tools.
- 4.8. The **washer drains** by gravity. An air activated two-way ball valve directs the discharge to the drain, resulting in a quick drain time.
- 4.9. The **washer tank capacity** is approximately 195-gallons of water, assuring effective cleaning and economy of operation. Level control is by means of a **stainless steel float switch, which is** tied into the washer control system.
- 4.10. **Heavy-duty stainless steel guide rails** will support and guide the pallets through the washer.
- 4.11. The washer is supplied with a four foot **infeed section** as well as a four foot **discharge section** to facilitate loading and unloading of pallets.
- 4.12. All four sides and top are **insulated** with rigid foam and covered with a full jacket. This insulation package greatly reduces radiated heat loss from the washer making it more economical to operate and affords more comfort for the operators.
- 4.13. The **door** is double walled and insulated with rigid foam insulation. It is also baffled and gasketed against water leakage from the wash chamber. The door gaskets are closed cell silicone. A **door**

- safety switch** located on the door. The switch stops the cycle and shuts down the washer operation in the event that the door is opened during a cycle.
- 4.14.  The wash tank is provided with a **steam heating coil** controlled by the control system (adjustable) to maintain the wash/rinse solutions at a pre-set temperature. A line strainer is supplied on the steam supply connection as well as condensate traps, where necessary.  
 The wash tank is provided with **electric immersion heaters** controlled by the control system (adjustable) to maintain the wash/rinse solutions at a preset temperature.
- 4.15. Drawer type **stainless steel tray screens** will be used, with perforations smaller than the jet openings to trap debris and protect the pump and spray orifices.
- 4.16. The **conveyor** consists of stainless steel belting and is designed to convey the pallets through the washer in a vertical position.  
1/2 Hp TEFC **gearhead motor**, arranged to carry the conveyor through the washer at a speed of 4 feet per minute. (Optional variable speed drive is available.)
- 4.17. **Pumps:**
- 4.17.1.  **Recirculating wash/rinse pump** is a T-316 stainless steel horizontal centrifugal type unit, powered by a 7-1/2 Hp motor. It is capable of delivering 200 gallons per minute at 100 ft head pressure.
- 4.17.2.  **Sanitary recirculating wash/rinse pump** is a T-316 stainless steel horizontal centrifugal type unit, powered by a 10 Hp motor. It is capable of delivering 200 gallons per minute at 100 ft head pressure.
- 4.18. **Potable water supply ball valves** are threaded connections.  
 **Steam supply ball valves** are threaded connections.
- 4.19. All **ancillary valves and equipment are positioned** on the washing machine top, rear and the side of the washer.
- 4.20. **Recirculation Headers** consist of properly spaced, wide-angle stainless steel machined fanjets welded in place. These jets direct the process solutions from the top, and both sides, assuring 360° continuous coverage of the items being processed.
- 4.21. **Rinse Header System** consists of a single spray loop spraying all outside surfaces at house temperature and pressure.
- 4.22. A **final rinse conservation switch** will be provided to allow the final rinse to operate only when a pallet is present in the rinse section.
- 4.23. **Tri-clamp connection** use **EPDM gaskets** and are connected by means of heavy-duty clamps with wing nuts.
- 4.24. **Seals, gaskets, and bearings** are compatible with the temperatures and concentrations of cleaning agents to be used. Customer will supply information on chemicals to be used.
- 4.25. A **compressed air system** is supplied with a filter regulator.
- 4.26. The washer is piped and wired for **single service connection** for each utility requirement.

## 5. CONTROLS AND OPERATION

- 5.1. The control system incorporates an **Allen Bradley Compact Logix @PLC**. This provides 512K of memory with Ethernet communication ability. The processor is aware of and controls all items on the washer. I/O cards are selected to match the control voltage. An isolated relay card is used to control high current draw items or items not operable at the control voltage. Analog cards are set to accept 4 - 20 mA inputs, unless otherwise noted.
- 5.2. The operator-machine consists of an **Allen Bradley Color Panelview Plus 600**, which incorporates a touch screen for operator control. This allows the user with proper password level to access all parameters of a wash recipe. All alarms are shown on the display, as well as announced audibly.
- 5.3. The washer is provided with the ability to use a printer to record operation reports. The customer should mount the printer close to the washer. Communication to the printer is RS232C so the maximum recommended distance from the washer is 50 ft. The report contains the following data: machine identification, operator, date and time, step name with time, temperature (min-max), etc.

- 5.4. A **typical treatment cycle** is defined as follows:  
 Load  
 Wash – Recirculated  
 Rinse – Non-Circulated  
 Unload
- 5.5. A total of **16 programs** can be stored in the PLC. Each program can be altered or developed from the OIT. Access to change or develop the programs is password protected.
- 5.6. Girton provides three levels of **password protection** to the control system:  
Operator Level – access to selection of existing programs only  
Maintenance Level – access to all maintenance screens  
Engineering Level – access to all levels. Allows changes to be made to existing programs and new programs to be developed.
- 5.7. Girton's control system provides the ability to **alarm on abnormal conditions**. The washer has alarms based on each I/O point failure. This provides a comprehensive way of determining a device failure or process deviation. In general, all analog inputs to the system will have low and high alarm points settable by the customer. Also, all safety devices, such as door switches or emergency stop buttons, have alarms associated with them.
- 5.8. **Fused disconnect switch** is supplied and located in the main electrical enclosure to cut power to the entire unit. The system is designed so if the disconnect is in the "ON" position the electrical enclosure is not be able to be opened.
- 5.9. The washer is equipped with **Emergency Stop** switches located at critical points on the machine. All doors are equipped with limit switches wired directly to the output voltage. Opening any door will disconnect voltage from output cards thereby shutting down the system. These switches are also wired as inputs to the PLC so that an alarm may be generated. All services are equipped with fail-closed-valves.
- 5.10.  See enclosed **Girton's Electrical Specification** for information on wiring, conduit, tagging, instrument installation and color-coding.
- 5.11. **Noise level** as measured from 3 ft. from the washer will be a **minimum of 85 dBa**.

## 6. DOCUMENTATION

- 6.1. **3 Hard copies and 1 electronic copy of Girton Documentation Package**. Validation requirements and considerations are playing an increasingly major role in the purchase of new equipment or systems. Validation requires documented evidence that the equipment or system will reliably perform in a manner consistent with the original design specifications. Generation of this documentation needs to be considered at the inception of the project and implemented throughout the design and manufacturing stages of the equipment. In most instances, the equipment vendor is the most qualified party to generate the majority of the required documentation.

The documentation provided by Girton Manufacturing Co., Inc. is designed to be a complete package including all data and checklists necessary to qualify the installation and operation of the equipment and/or system. All equipment built by Girton is completely factory assembled and tested. The documentation is used to perform Factory Acceptance Testing; witnessed and approved by the customer. All tests necessary for Installation and Operation Qualification of the equipment are performed on the equipment prior to its arrival on the job-site. Any modifications or additions required to qualify the equipment can be made at the factory prior to shipment.

This index lists all documentation supplied by Girton Manufacturing Co., Inc.

### 1 DRAWINGS

#### **DRAWINGS**

Installation/General Arrangement

P&ID – Piping and Instrumentation Drawing

#### **ELECTRICAL SCHEMATICS & PANEL DRAWINGS**

ELECTRICAL SCHEMATICS - 3 Phase Wiring Diagrams, Control Wiring Diagrams, I/O Wiring Diagrams

PANEL LAYOUTS - PLC Panel Layout, Motor Starter Panel Layout

AIR PIPING SCHEMATICS

## **2 EQUIPMENT DATA**

### **INSTRUMENT LIST**

Tag numbers, manufacturer, model number, serial number, and description for all instruments installed on the washer.

### **MECHANICAL EQUIPMENT LIST**

Component description, manufacturer, model number, and materials of construction.

### **CONTROL SYSTEM COMPONENT LIST**

Tag numbers, manufacturer, model number, serial number, and description for all control system components installed on the washer.

### **EQUIPMENT LUBRICATION LIST**

List of lubricants used to maintain the washer.

### **USER MANUAL**

Instructions for operating the equipment including loading, unloading, control system operation, and safety precautions. Maintenance schedules and repair procedures for all equipment and instruments.

### **CALIBRATION AND CERTIFICATION**

Calibration sheets, certifications and procedures for calibrating all critical instruments provided by Girton.

### **(SHORT TERM) PRICED SPARE PARTS LIST**

#### **PRICED SPARE PARTS LIST**

Listing of replacement parts and their corresponding order numbers. Instructions on information required when ordering replacement parts.

#### **COMPONENT CATALOG BROCHURES**

Manufacturer's catalog information concerning installation, operation, and maintenance procedures for all purchased mechanical equipment and instruments.

#### **CUSTOMER SERVICE POLICY**

Tells about the warranty, damages, replacement parts, returned merchandise, field service, cancellation, and special equipment.

## **3 SOFTWARE DATA**

### **QUALITY AND PROJECT PLAN**

Defines the quality and project objectives for the washer and its automated control system.

### **FUNCTIONAL SPECIFICATION**

Outlines functional requirements for the equipment.

### **HMI & PLC DESIGN SPECIFICATIONS**

This document defines the hardware and software specifications for the washer and its component parts. The purpose of this document is to describe the complete operation of the automated process control system for the washer.

### **PROGRAMS ON CD**

#### **RS VIEW**

Reports generated by the display software, which define screen elements and tag numbers corresponding to PLC addresses.

#### **PLC RS LOGIX 500 PROJECT REPORT**

Annotated listing of all code used to implement the software design.

## **4 FACTORY ACCEPTANCE TEST**

ABXXX FAT Instructions / Reference

ABXXX Section 02 FAT Approval Drawing Review Test

ABXXX Section 03 FAT Instrument Tests

ABXXX Section 04 FAT Mechanical Equipment Tests

ABXXX Section 05 FAT Electrical Tests

ABXXX Section 06 FAT Utility Tests

ABXXX Section 07 FAT Control System Hardware Tests

ABXXX Section 08 FAT Control System Software Tests

ABXXX Section 09 FAT Calibration Tests  
ABXXX Section 10 FAT HMI Tests  
ABXXX Section 11 FAT Operation Tests  
ABXXX Section 12 FAT Alarm Tests  
ABXXX Section 13 FAT Power Failure Tests  
ABXXX Section 14 FAT Summary Report Tests  
ABXXX Section 15 FAT Project Tests  
ABXXX FAT Signature Log  
ABXXX FAT Instrument Log  
ABXXX FAT Exception Log  
ABXXX FAT Test Progress Sheet  
ABXXX FAT Exception Form

## **5 PASSIVATION & PUNCHLIST REPORTS**

Passivation Procedure  
Passivation Report  
Completed Punchlist

### **VOLUME 3 OF 4**

## **6 SITE ACCEPTANCE TEST**

ABXXX SAT Instructions / Reference  
ABXXX Section 02 SAT Approval Drawing Review Test  
ABXXX Section 03 SAT Instrument Tests  
ABXXX Section 04 SAT Mechanical Equipment Tests  
ABXXX Section 05 SAT Electrical Tests  
ABXXX Section 06 SAT Utility Tests  
ABXXX Section 07 SAT Control System Hardware Tests  
ABXXX Section 08 SAT Control System Software Tests  
ABXXX Section 09 SAT Calibration Tests  
ABXXX Section 10 SAT HMI Tests  
ABXXX Section 11 SAT Operation Tests  
ABXXX Section 12 SAT Alarm Tests  
ABXXX Section 13 SAT Power Failure Tests  
ABXXX Section 14 SAT Summary Report Tests  
ABXXX Section 15 FAT Project Tests  
ABXXX SAT Signature Log  
ABXXX SAT Instrument Log  
ABXXX SAT Exception Log  
ABXXX SAT Test Progress Sheet  
ABXXX SAT Exception Form

## **7 WELDING**

Procedure Qualification Record (PQR)  
Weld Procedure Specifications (WPS)  
Welding Procedure Qualifications (WPQ)  
Weld Inspector Qualifications  
Weld Logs and Weld Maps.

## **8 CERTIFICATIONS**

Material Certifications sent with raw materials and some instruments ordered specifically for this project  
Work Order Trace Report  
Material Test Reports  
Certificates of Conformance/Compliance

## 7. SERVICE REQUIREMENTS

- 7.1. **Electrical:** 3 phase, 60 cycle, 208 230 460 volt, \_\_\_\_\_ amperes.
- 7.2. **Hot Water:** 180°F. Recommended minimum rate of flow of 20 gallons per minute. 1" NPT connection to the machine. 8-gallon consumption/rate for fresh rinse.
- 7.3. **Steam:** 40 to 80 PSI. 1" NPT connection to the machine (for most efficient operations, 60 PSI is recommended). 620-lb./hr. requirement.
- 7.4. **Condensate:** 3/4" NPT.
- 7.5. **Drain:** 2" NPT from the machine to the drain.
- 7.6. **Ventilation:** 10" diameter vent collar is provided for connection to ventilating system. 1,300 CFM minimum removal required. Connection should be installed inside of vent collar to prevent leakage.

## 8. WARRANTY

- 8.1. Girton Manufacturing Co., Inc. warrants equipment of original manufacture against defect in workmanship and material for a period of one year from date of shipment. Provided; however, the equipment has been operated under normal working conditions for such said equipment, that it has been properly serviced and cared for, and that no adjustments have been made by unauthorized personnel that could adversely affect the operation or life of the equipment.

Girton Manufacturing Co., Inc. will replace or repair defective merchandise at its plant, FOB Millville, PA, if after inspection; the equipment or components that Girton manufactured are defective. Girton Manufacturing Co., Inc. extends to its customers on all purchased components parts, the warranty of the supplier of such said parts.

No expense, liability, or responsibility will be assumed by Girton for repairs outside Girton's factory, without written authority from Girton Manufacturing Co., Inc.

The foregoing warranty excludes all other warranties, guaranties, and/or representations; whether expressed, implies, or oral, INCLUDING, BUT NOT LIMITED TO, ALL CONDITIONS AND EXCLUSIONS OF IMPLIED WARRANTY OF MERCHANTABILITY AND OR FITNESS FOR THE PURPOSE, and the warrantor's liability for any direct damage arising from a legally proven breach of the warranty hereby extended is limited to the customer's invoice cost of the goods warranted.

- 8.2. DISCLAIMER OF CONSEQUENTIAL DAMAGES LIABILITY - Girton Manufacturing Co., Inc. shall not be liable for consequential damages of any kind, including incidental labor or other costs.

## 9. CANCELLATION

- 9.1. Any order on which work had been started may be cancelled only by consent of Girton Manufacturing Co., Inc. and by agreement on the part of the purchaser to cover whatever cost has been incurred, if any, to the date of the cancellation, including engineering, administrative, material purchases, labor, and overhead expended.

## 10. CUSTOMER TO WITNESS PRELIMINARY FACTORY ACCEPTANCE TEST (FAT)

- 10.1. Customer may witness preliminary testing performed at Girton Manufacturing Co., Inc. prior to shipment to customer's facility.

Customer will supply adequate samples of the items being washed. If customer specifies a particular chemical to be used, they shall supply it, complete with a MSDS Report. Customer shall be responsible for disposal or removal of excess chemical from premises.

- 10.2. **Factory Acceptance Test (FAT)** – Girton Manufacturing Co., Inc. will provide the necessary personnel for a maximum of 3 days to assist with the Factory Acceptance Test (FAT). The Girton Factory Technicians will work with the customer's personnel in verifying the washer is built and operates according to the FAT documentation.

## 11. DOCUMENTS

- 11.1. \_\_\_ # sets of **Approval Documents** will be provided to the Customer in \_\_\_ days weeks after receipt of order. Production work will not be initiated until these drawings are returned to Girton Manufacturing Co., Inc. with the appropriate signatures of the customer.

## 12. INSTALLATION

- 12.1. Installation will be **done by others**.

**Supervision of installation by Girtons** - Girton Manufacturing Co., Inc. will provide a technician for \_\_\_\_\_ (*# of days*) who will work with the customer's in-house personnel or with an outside contractor. The technician(s) will provide instructions for all phases of re-assembly including moving the equipment, leveling, re-assembly, and connection to utilities for an additional fee.

**Set-in-place installation by Girtons -**

Girton Manufacturing Co., Inc. will provide the necessary non-union labor to re-assemble the equipment and make it ready for utility connections at the customer's site. The customer will be responsible for receiving the equipment, unloading and moving it to the area where it is to be installed prior to Girton's arrival and for connecting the utilities.

Girton Manufacturing Co., Inc. will provide the necessary union labor to re-assemble the equipment and make it ready for utility connections at the customer's site. The customer will be responsible for receiving the equipment, unloading and moving it to the area where it is to be installed prior to Girton's arrival and for connecting the utilities.

**Complete installation by Girtons**

Girton Manufacturing Co., Inc. will provide the necessary non-union labor and material to perform a complete installation of the equipment. This includes receiving the equipment at the customer's site, unloading, uncrating, move in place, re-assembly and connection to existing utilities. The utilities must be within 4 feet from the equipment.

Girton Manufacturing Co., Inc. will provide the necessary union labor and material to perform a complete installation of the equipment. This includes receiving the equipment at the customer's site, unloading, uncrating, move in place, re-assembly and connection to existing utilities. The utilities must be within 4 feet from the equipment.

## 13. TERMS AND CONDITIONS

- 13.1. Payment Terms:  
Please consult factory.
- 13.2. The 6% PA sales tax will be assessed on all sales. If you believe the products covered by this proposal are exempt from this tax, please send to Girton Manufacturing Co., Inc. your PA sales tax exemption certificate.

## 14. SHIPPING

- 14.1. Freight terms:  
Collect  
Prepaid by customer and add to Invoice  
Third Party Billing
- 14.2. Shipment will be provided by transportation arranged by Girton Manufacturing Co., Inc.  
customer.
- 14.3. Shipment from Millville, PA \_\_\_ to \_\_\_ weeks, after receipt of signed Documents by Girton Manufacturing Co., Inc.

## 15. TOTAL COST PER SPECIFICATION, CONSULT FACTORY



## 16. OPTIONS

- 16.1. The Human Machine Interface (HMI), mounted on the washer, consists of a PLC based display, which will be programmed using RSView SE software, which incorporates a touch screen for operator control and monitoring. This allows the user with proper password level to access all parameters of a wash recipe. All alarms are shown on the display, as well as announced audibly. Use of this system complies with CFR21 Part 11.
- 16.2. **T-316L construction** on all wetted surfaces with the exception of distribution hoses.
- 16.3. **Interior finish** to be a 35Ra or better finish.
- 16.4. **Air blow-off section**, to remove excess moisture from the surface of the pallets. A pressure blower is used to distribute air through stainless steel plenum onto all surfaces of the pallets. This option adds five feet to the overall length of the washer.
- 16.5. **Heated air blow-off** - The air blow-off consists of a recirculated hot air system utilizing  steam coils  electric heating elements and a high volume blower to circulate hot air over the items to be dried. A small amount of room air is drawn into the system to aid in maintaining proper humidity levels for efficient drying. The controller controls the drying cycle and temperature.
  - 16.5.1.  Heating surface is fabricated of copper tubes with aluminum fins. Blower is fabricated of painted steel.
  - 16.5.2.  Stainless steel air stream of  T-304  T-316L. Blower is fabricated of  T-304  T-316L stainless steel. A HEPA filter is provided on discharge of blower.
- 16.6. A **light fixture** mounted on the exterior of the unit illuminates the wash chamber during operation.
- 16.7. The discharge pressure of the main circulation pump is monitored using a **sanitary pressure transmitter**. This pressure is recorded and alarmed by the control. The diaphragm of the sensor is attached in the wash pump discharge line using a tri-clamp connection. Girton's standard range for measuring pump pressure is 0 to 100 psi. Girton's preferred vendor is Rosemount for the instrument.
- 16.8. A **sample port** in the recirculation sump allows sampling of the water from the face of the washer. The sample port is attach via tri-clamp with connecting piping to have sufficient pitch in order to drain back into the washer recirculation tank, thus eliminating the possibility of dead legs.
- 16.9. A **drain tempering system** cools the process wash and rinse solutions from 180° F to 140° F prior to entering the customer's drain. This system consists of a temperature control with a probe located in drain line for on-off control of cold water supply valve.
- 16.10. The **conductivity** of any wash solution where a reagent is added is monitored, recorded and, if needed, alarmed by the control. A sensor is attached either in the wash pump discharge or directly into the sump. Both are inserted into a sanitary tri-clamp connection. Girton's standard range for measuring wash solution conductivity is 0 to 100 milli-siemens.
- 16.11. The **conductivity** of the final rinse with the customer's designated water will be monitored, recorded and, if needed, alarmed by the control. The sensor is attached in or near the drain line with a sanitary tri-clamp connection. Girton's standard range for measuring final rinse conductivity is 0 to 100 micro-siemens.
- 16.12. **Girton neutralization system** will be provided for the purpose of neutralizing the wash solution before going to drain. This system will include a **chemical pump** to inject the neutralizing solution and the necessary divert valves to stop the flow of water from going to the headers and direct it back to the washer sump to mix the neutralizing solution.
- 16.13. **Girton neutralization system with pH monitor** will be provided for the purpose of neutralizing the wash solution before going to drain. This system will include a **chemical pump** to inject the neutralizing solution and the necessary divert valves to stop the flow of water from going to the headers and direct it back to the washer sump to mix the neutralizing solution. The pH sensor will signal the washer PLC when the solution had reached the desired level so the drain valve can open.
- 16.14. **Automatic detergent dispenser** is provided with the control system. One (1) peristaltic pump with 120VAC motors is used to charge the wash solution with the desired reagent. The customer sets the amount of time that each dispenser will run for the wash cycle.

- 16.15. For each reagent reservoir, Girton supplies a **level monitor**. The monitor will consist of an ultrasonic sensor that will switch a PLC input when the reagent reaches the specified level. The control can then either trigger an alarm or a status message based on the input. The sensor has threads allowing it to be mounted into the lid of the customer's detergent reservoir.
- 16.16. A **remote mounted Epson LX300 printer** will be provided so that a printed record of each cycle can be obtained.
- 16.17. The washer is specified to be in a **Class I Division 2 Group D area**. All wiring, conduit, instruments, and other devices conform to the NEC and NFPA regulations for the class and division of the washer. If required, purged enclosures will be provided as well as explosion resistant conduit.
- 16.18. All **conduit** on the machine are PVC coated rigid. Fittings and conduits are PVC coated as well. Liquid tight flexible conduit is used to connect the washer's devices. Lengths of flexible conduit do not exceed 3 feet. All marks on conduit are painted with PVC paint. All conduit installation meets the current NEC requirements.
- 16.19. All controls are rated at **24VDC**, if possible. Items not able to operate at 24VDC have a control relay that will provide contacts usable at 120VAC.
- 16.20. Each motor under control have a locally mounted **HAND-OFF-AUTO** switch and a "Run" light. In HAND position, the motor runs; in OFF position, the motor stops; in AUTO position, the motor is under PLC control.
- 16.21. An **exhaust fan**, wired and mounted on machine, including manual damper, is provided. The fan will exhaust 1,300 CFM to the ventilating system or to the outside. A 10" diameter vent collar is also provided. The connection is installed inside of vent collar to prevent leakage.
- 16.21.1.  Epoxy painted air-steam.
- 16.21.2.  T-304  T-316L stainless steel air-steam.
- 16.22. The wash tank is provided with **electric immersion heaters** controlled by the control system (adjustable) to maintain the wash/rinse solutions at a preset temperature.
- 16.23. A **pass-through heat exchanger** raises the incoming potable water temperature from 140°F to 180°F.
- 16.24. **Sanitary pump liquid filled pressure gauge** with tri-clamp connections are supplied and located in the pump discharge piping to allow visual inspection of actual pump pressure.
- 16.25. **Additional copies of our Documentation Package** (reference item # \_\_\_\_\_ of this specification) may be purchased.
- 16.26. **Optional Documentation:**
- 16.26.1. Surface Finish Map and Certificate of Compliance
- 16.26.2. Slope Map of Process Contact Tubing and Certificate of Compliance
- 16.26.3. Video Weld Logs
- 16.26.4. Sound Level Certificate of Conformance
- 16.27. **Supervision of installation (YSOFI)** – Girton Manufacturing Co, Inc. will provide ONE Qualified Technician for \_\_\_\_ (# of days) contiguous\* on-site days to Supervise and Direct Customer Personnel, Contractors or Subcontractors in all phases of Installation. This includes oversight of Uncrating and Moving the Equipment into a prepared<sup>(1)</sup> Wash Room, Leveling and Reassembly, Utility<sup>(2)</sup> and Additional Support Systems<sup>(3)</sup> Connections. Supervision of Unloading the Shipping Truck will be performed *only if* delivery occurs during the scheduled timeframe.
- Supervision of Installation (SofI) does **not** include Sub-Contracting, Equipment or Tools or Tool Rental, Dumpsters and/or Trash Disposal, Multiple Trips from our Factory (except at our discretion and as deemed necessary by our Technical Service Manager), Additional Site Preparation, Materials for Floor Protection, Integration Materials or Fabrication (other than Modular Walls, Fascia Panels, and items purchased from Girton Mfg. as an option), Equipment Start Up, Training of Personnel or Assisting with SAT or Validation Documentation.
- The Customer will be responsible for all facets of installation not specifically included above. Equipment Start Up, Training of Personnel, Assisting with SAT or Validation Documentation may be purchased from Girton separately.

A Field Report will be submitted to the Customer within one week of completion of the installation.

Supervision of Installation is a quoted option and valid as part of the original equipment order. Service ordered after the original equipment order date will require a re-quote. Travel expenses are included in the first day billing. Additional contiguous days may be purchased for a flat fee of \$\_\_\_\_.00 per day, but should be purchased prior to the first on-site day, if possible. This information is based on non-union labor. Special provisions and prices apply when union labor and/or prevailing wages are required. Contact your Sales Rep for further details.

- 16.28. **Set-in-place Installation (YSIP)** - Girton Manufacturing Co, Inc. will provide Qualified Technicians for \_\_\_\_ (# of days) contiguous\* on-site days to Unload and Uncrate, Move the equipment to a prepared<sup>(1)</sup> location, Reassemble and Level the Equipment. Girton Manufacturing Co, Inc. will provide all Personnel, Material, Tools and Equipment to perform the task, including Fork Trucks, Dumpsters, Welders, Hand Tools, Floor Protection and Trash Elimination.

Set-In-Place Installation (SIP) does **not** include Utility<sup>(2)</sup> Connections, Connection of Additional Support Systems<sup>(3)</sup>, Multiple Trips from our Factory (except at our discretion and as deemed necessary by our Technical Service Manager), Additional Site Preparation, Integration Materials or Fabrication (other than Modular Walls, Fascia Panels, etc., purchased from Girton Mfg. as an option), Equipment Start Up, Training of Personnel or Assisting with SAT or Validation Documentation.

The Customer will be responsible for all facets of installation not specifically included above. Equipment Start Up, Training of Personnel, Assisting with SAT or Validation Documentation may be purchased from Girton separately.

A Field Report will be submitted to the Customer within one week of completion of the installation.

Set-In-Place Installation is a quoted option and valid as part of the original equipment order. Service ordered after the original equipment order date will require a re-quote. Travel expenses are included in the first day billing. Additional contiguous days may be purchased for a flat fee of \$\_\_\_\_.00 per 8 Hr. man-day, but should be purchased prior to the first on-site day, if possible.

This information is based on non-union labor. Special provisions and prices apply when union labor and/or prevailing wages are required. Contact your Sales Rep for further details.

- 16.29. **Complete Installation (YINSTALL)** - Girton Manufacturing Co, Inc. will provide Qualified Technicians for \_\_\_\_ (# of days) contiguous\* on-site days to Unload, Uncrate, Move the equipment to a prepared<sup>(1)</sup> location, Reassemble, Level the Equipment and Connect Utilities<sup>(2)</sup> to **existing stubs** within 6' of the machine. Girton Manufacturing Co, Inc. will provide all Personnel, Material, Tools and Equipment to perform the task, including Fork Trucks, Dumpsters, Welders, Hand Tools, Floor Protection and Trash Elimination. Test and Demonstration (see below) is part of this option. If this cannot be completed contiguously (due to unavailable utilities, Customer personnel availability, etc.), a return trip must be scheduled and additional travel expenses will apply.

Complete Installation (CI) does **not** include Multiple Trips from our Factory (except at our discretion and as deemed necessary by our Manager), Additional Site Preparation, Connection of Additional Support Systems<sup>(3)</sup>, Integration Materials or Fabrication (other than Modular Walls, Fascia Panels, etc., purchased from Girton Mfg. as an option), Equipment Start Up, Training of Personnel or Assisting with SAT or Validation Documentation.

The Customer will be responsible for all facets of installation not specifically included above. Equipment Start Up, Training of Personnel, Assisting with SAT or Validation Documentation may be purchased from Girton separately.

A Field Report will be submitted to the Customer within one week of completion of the installation.

Complete Installation is a quoted option and valid as part of the original equipment order. Service ordered after the original equipment order date will require a re-quote. Travel expenses are included in the first day billing. Additional contiguous days may be purchased for a flat fee of \$\_\_\_\_.00 per 8 Hr. man-day, but should be purchased prior to the first on-site day, if possible.

This information is based on non-union labor. Special provisions and prices apply when union labor and/or prevailing wages are required. Contact your Sales Rep for further details.

- 16.30. **Test and Demonstration (YTD)** - Girton Manufacturing Co, Inc. will provide ONE Qualified Technician for \_\_\_\_ (# of days) contiguous\* on-site days to perform Start Up Testing, such as verifying utility connections and capacities, electrical supply voltage and amperage, motor rotations, completeness of assembly, missing components, etc., on fully installed<sup>(4)</sup> equipment. The Technician will make normal *equipment* adjustments and test operation against factory standards. Upon

completion of satisfactory testing, the Technician will demonstrate all phases of the use and operation of the equipment to any interested parties, provided sufficient time is allotted. We recommend that three to four hours be dedicated for effective demonstration. We highly recommend that at least one User of each level of access (Operator, Maintenance, Supervisor/Engineering, Administrative) be present for the demonstration. *Demonstration must not be confused with training; it is NOT a substitute for a complete and formal training session*, 'Demonstration' is informal, with the Technician covering the highlights of the equipment and operation and hazard awareness, and answering questions from interested parties. No handout sheets or post-training testing is given.

Test and Demonstration (T&D) does **not** include mechanical reassembly or completion of wiring or pneumatics (on-skid or otherwise), any function that is normally part of the three Installation options described above, Multiple Trips from our Factory (except at our discretion and as deemed necessary by our Technical Service Manager), Additional Site Preparation, or Assisting with SAT or Validation Documentation.

The Customer will be responsible for all facets of installation not specifically included above. Supervision of Installation, Set in Place Installation, Complete Installation, Training of Personnel, Assisting with SAT or Validation Documentation may be purchased from Girton separately.

A Field Report and a copy of an Attendance Record for the demonstration will be submitted to the Customer within one week from the end of the visit.

Test and Demonstration is a quoted option and valid as part of the original equipment order. Service ordered after the original equipment order date will require a re-quote. Travel expenses are included in the first day billing. Additional contiguous days may be purchased for a flat fee of \$\_\_\_\_.00 per 8 Hr. man-day, but should be purchased prior to the first on-site day, if possible.

This information is based on non-union labor. Special provisions and prices apply when union labor and/or prevailing wages are required. Contact your Sales Rep for further details.

- 16.31. **Start Up (YSTART)** - Girton Manufacturing Co, Inc. will provide ONE Qualified Technician for \_\_\_\_ (# of days) contiguous\* on-site days to perform Start Up Testing, such as verifying utility connections and capacities, electrical supply voltage and amperage, motor rotations, completeness of assembly, missing components, etc., on fully installed<sup>(4)</sup> equipment. The Technician will make normal *equipment* adjustments and test operation against factory standards. Start Up does **not** include mechanical reassembly or completion of wiring or pneumatics (on-skid or otherwise), any function that is normally part of the three Installation options described above, Multiple Trips from our Factory (except at our discretion and as deemed necessary by our Technical Service Manager), Additional Site Preparation, or Assisting with SAT or Validation Documentation.

The Customer will be responsible for all facets of installation not specifically included above. Supervision of Installation, Set in Place Installation, Complete Installation, Training of Personnel, Assisting with SAT or Validation Documentation may be purchased from Girton separately.

A Field Report will be submitted to the Customer within one week from the end of the visit.

Start Up is a quoted option and valid as part of the original equipment order. Service ordered after the original equipment order date will require a re-quote. Travel expenses are included in the first day billing. Additional contiguous days may be purchased for a flat fee of \$\_\_\_\_.00 per 8 Hr. man-day, but should be purchased prior to the first on-site day, if possible. This information is based on non-union labor. Special provisions and prices apply when union labor and/or prevailing wages are required. Contact your Sales Rep for further details.

- 16.32. **Training (YTR)** - Girton Manufacturing Co, Inc. will provide ONE Qualified Technician for \_\_\_\_ (# of days) contiguous\* on-site days to formally and thoroughly provide in-depth training to Operators, Maintenance Technicians, Engineering and Administrative Level Personnel. Our Technician will provide a combination of classroom and hands-on field training. A 'Question and Answer' period is encouraged.

16.32.1. **Topics covered are:**

Hazard Awareness,  
Alarms and the causes of and responses to them,  
Routine Operation,  
Routine Maintenance and Trouble Shooting,  
Set Up, Management and Modification of Recipes (Cycles),  
User Management (Administration).

- 16.32.2. **Training (TRN)** covers the full range of access and use:

- 16.32.2.1. **'Operator'** level training covers the daily operation and maintenance, and is the shortest and most basic training.
- 16.32.2.2. **'Maintenance'** level training includes full Operator training and adds the extensive maintenance diagnostic capabilities available through the HMI, and PM requirements.
- 16.32.2.3. **'Engineering'** level training will include condensed Operator and Maintenance coverage and adds in-depth Recipe (Cycle) Generation and Management and Recipe and Alarm Set Points. Engineering training is typically restricted to those individuals responsible for control of validated operation.
- 16.32.2.4. **'Administrator'** level training will have condensed coverage for all levels of use, but will focus primarily on User Administration and Security. At this level, Users Names and Passwords are assigned and Levels of Access Controlled.

Whenever possible, a computer presentation will be shown and pertinent hand out sheets will be distributed. An Attendance Roster and post-training Retention Test will be given and copies will be provided to the Customer.

Training is a quoted option and valid as part of the original equipment order. Service ordered after the original equipment order date will require a re-quote. Travel expenses are included in the first day billing. Additional contiguous days may be purchased for a flat fee of \$\_\_\_\_\_.00 per day, but should be purchased prior to the first on-site day, if possible. This information is based on non-union labor. Special provisions and prices apply when union labor and/or prevailing wages are required. Contact your Sales Rep for further details.

- 16.33. **Site Acceptance Testing Assistance (YSAT)** - Girton Manufacturing Co, Inc. will provide ONE Qualified Technician for \_\_\_\_ (# of days) contiguous\* on-site days to assist the Customer's Validation Group(s) with IQ/OQ of fully installed<sup>(4)</sup> and running equipment. Girton Mfg. will provide an SAT Template based on the factory test documents and appropriate programming software and test instruments necessary to duplicate the factory tests. Girton Technicians will assist the Customer by providing clarification of test procedures and test results, and through our experience with the PLC and HMI Programming. Sample SAT documents are typically submitted to the Customer for early review. Machine specific documents shall be submitted to the Customer a minimum of two weeks prior to SAT.

Girton Technicians will *not* be responsible for completing partial installations, test document revisions or test completion.

A Field Report will be submitted to the Customer within one week of completion of the SAT.

Site Acceptance Test is a quoted option and valid as part of the original equipment order. Service ordered after the original equipment order date will require a re-quote. Travel expenses are included in the first day billing. Additional contiguous days may be purchased for a flat fee of \$\_\_\_\_\_.00 per day, but should be purchased prior to the first on-site day, if possible. This information is based on non-union labor. Special provisions and prices apply when union labor and/or prevailing wages are required. Contact your Sales Rep for further details.

**16.34. Notes:**

- 16.34.1. <sup>(1)</sup> "Prepared" site is defined as one at which the building is enclosed, the floor and floor coatings are complete and where Girton personnel can work reasonably unhindered. Electricity (for tools) *must* be available. It is preferred, but not mandatory, that utilities<sup>(2)</sup> are complete and available.
- 16.34.2. <sup>(2)</sup> "Utilities" are defined as Potable Water (Hot and/or Cold), Steam, Condensate, Ventilation, Electrical, Compressed and/or Instrument Air, and Drains. "Utilities" does *not* include Purified (DI, WRO, WFI, etc.) water sources that require high-purity pipe welding, remote Detergent systems or controls, Chiller/Glycol system piping, Facility Control or Data Systems, networked or otherwise.
- 16.34.3. <sup>(3)</sup> "Additional Support Systems" are defined as Purified Water (DI, WRO, WFI, etc.), Chiller systems, Detergent Systems, Combustible Liquids or Gas, and Breathing Air. Connection of Additional Support Systems is *always* the responsibility of the Purchaser.
- 16.34.4. <sup>(4)</sup> "Fully Installed" is defined as the equipment being in-place and leveled, and connected to all utilities and additional support systems. Integration with building fabric is not required.

\* Excluding Saturdays, Sundays and/or Holidays, unless prearranged.

## GIRTON MODEL CW10PS VENDOR LIST

<b><u>COMPONENT</u></b>	<b><u>VENDOR</u></b>
Controller	Allen Bradley
Limit Switches	Allen Bradley
Temperature Transmitter	Burns
Level Switch	Madison Inc.
Jets	Spraying Systems
Transformer	Square D
Motor Starters	Square D
Terminal Strip	Square D
Fuses and Fuse Holder	Ferraz Shawmutt
<input type="checkbox"/> Recirculation Pump	Ampco
<input type="checkbox"/> Sanitary Recirculation Pump	Ampco
Ball Valves - Pneumatic Actuators	Duravalue
Compressed Air Filter Regulator	ASCO
<input type="checkbox"/> Valve (For Steam)	Duravalue
Solenoid Valve (For Pneumatic Actuators)	SMC
<input type="checkbox"/> Condensate Traps	Sarco
Sanitary Diaphragm Valve	ITT
Disconnect Switch	Square D
Emergency Stop Switch	Allen Bradley
 <b><u>OPTIONS</u></b>	
Drying System	
A. Blower	Girton
B. Steam Coils	Super Radiator Coil
C. Steam Control Valve	Duravalue
D. Condensate Trap	Sarco
Dryer HEPA Filter	American Air Filter
Indicating Pressure Transmitter	Rosemount or Equal
Sample Port	Tri Clover
Drain Tempering System	
A. Cold Water Control Valve	Duravalue
B. Manual Throttling Valve	Duravalue
Conductivity Sensors	Thornton
Detergent Dispenser	Knight Equipment Co.
Chemical Container Level Sensors	Carlo Gavazzi
Exhaust Fan	Girton
Electric Heating Elements	Indeeco

A. Electric Contractors  
Heat Exchanger for Potable Washer  
A. Steam Regulating Control Valve  
Pump Pressure Gauge

Allen Bradley  
Graham  
Sarco  
Tri Clover



# Girton Pallet Washer

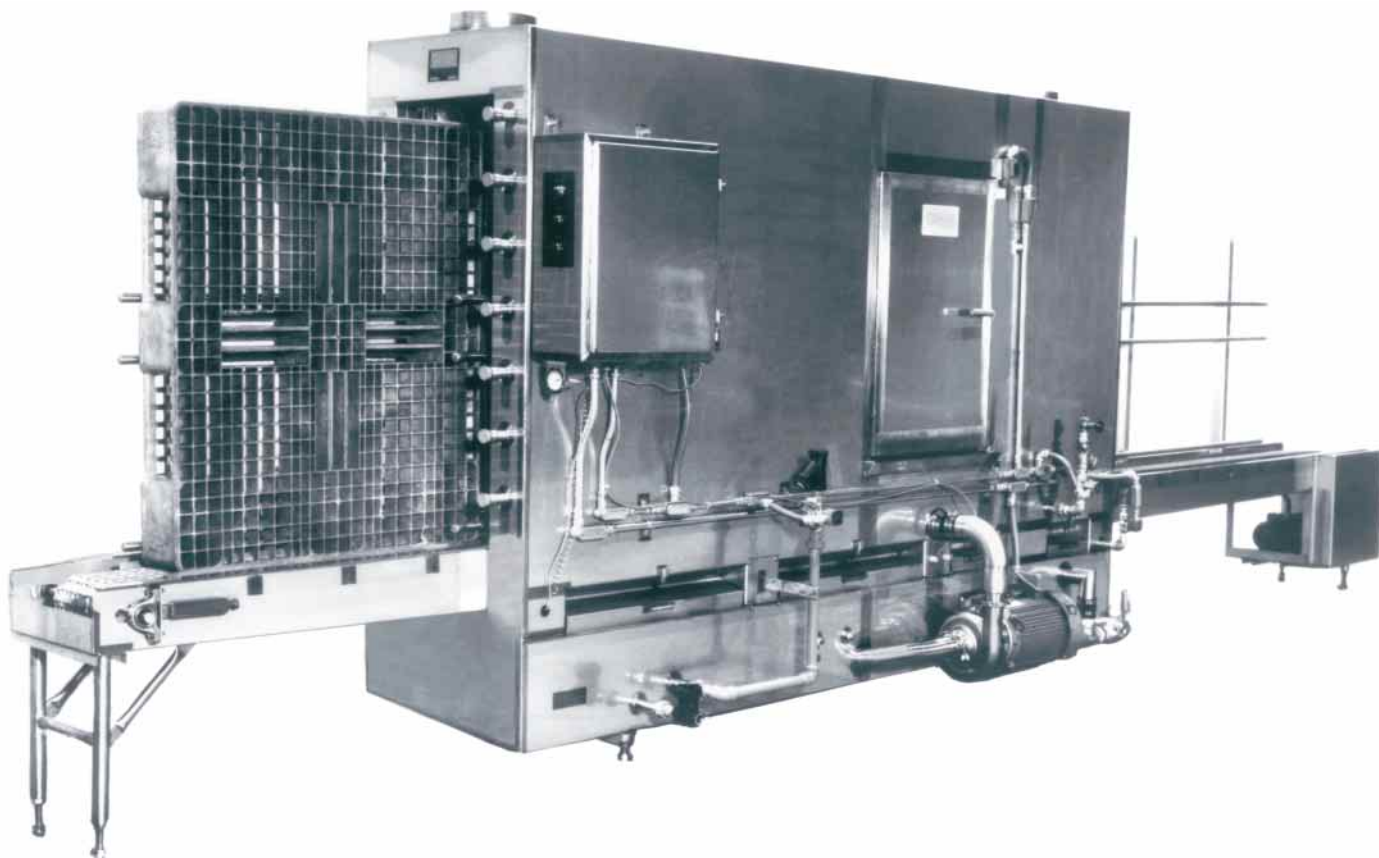

## **Features:**

- All stainless steel construction
- Variable-speed conveyor — to carry pallets thru the washer in a vertical position
- 3 screens to protect pump and jets
- 10HP wash pump delivers 350GPM at 80' head pressure
- Fresh rinse header using water from plant supply
- Automatic steam temperature controls for wash
- Special jet design provides efficient cleaning
- 10" I.D. exhaust connections

## **Available Options:**

- Stainless steel pump
- Air blow-off section — removes excess moisture from pallets
- Shut off switch for conveyor and fresh rinse when pallet is not removed

The Girton logo consists of the word "Girton" in a white, bold, sans-serif font, enclosed within a white rectangular border. This logo is set against a solid blue rectangular background.

## **Girton Manufacturing Co., Inc.**

P.O. Box 900 • Millville, PA 17846-0900

phone: 570.458.5521

fax: 570.458.5589

website: [www.girton.com](http://www.girton.com)

e-mail: [info@girton.com](mailto:info@girton.com)

*Meeting the needs of the food industry since 1927.*

# Girton Pallet Washer

## Dimensions

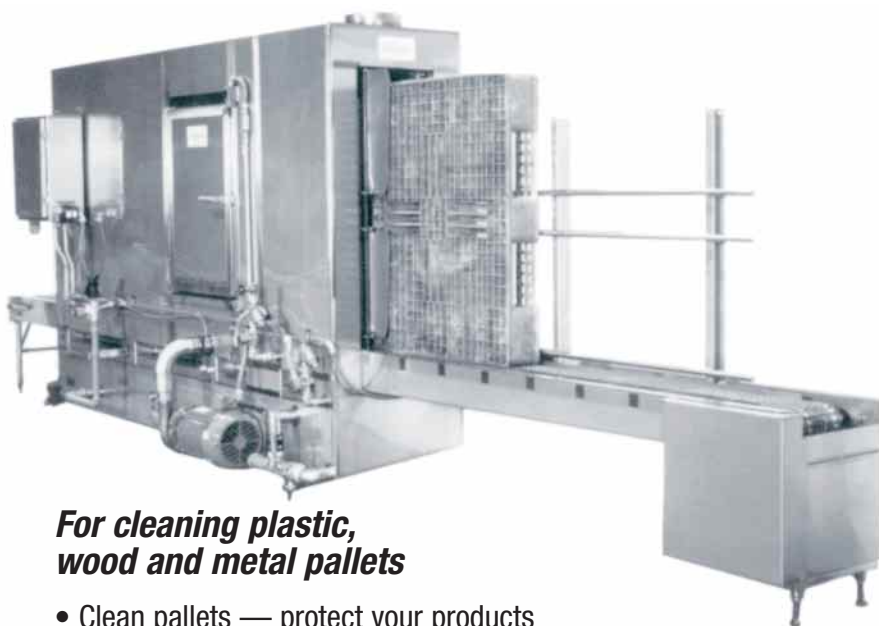
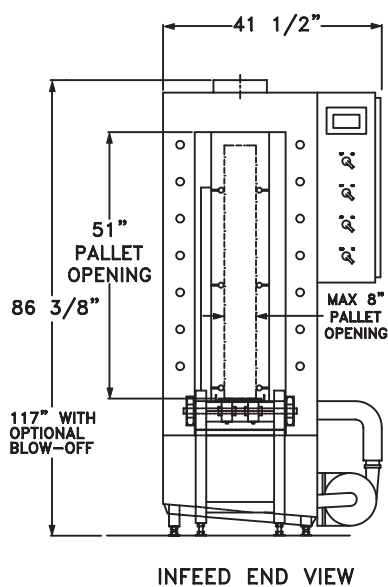
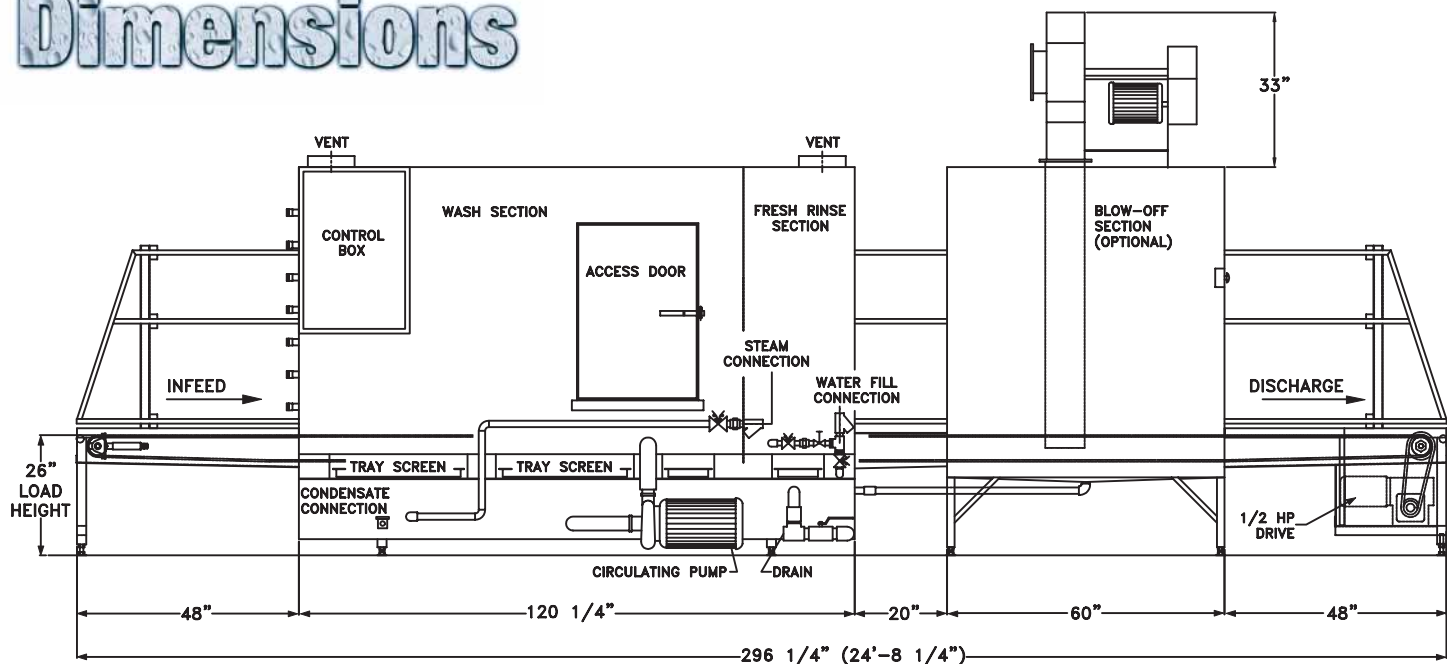

**For cleaning plastic,  
wood and metal pallets**

- Clean pallets — protect your products  
— extend pallet life — improve plant sanitation
- Clean 60 to 180 pallets per hour
- Completely assembled for easy installation, hook-up the water, steam and electrical — washer is ready to go